



INTELLIFLOXF®



INTELLIFLO XF[®] VARIABLE SPEED PUMP

Our most energy efficient pump yet!



pentairpool.com

THE PUMP THAT STARTED AN ENERGY-SAVING REVOLUTION...

AN ECO SELECT® BRAND PRODUCT

The Eco Select brand identifies our "greenest" and most efficient equipment choices. By combining the superior internal geometry of new-generation XF pumps with game-changing variable speed technology, the IntelliFloXF® Variable Speed Pump delivers the greatest energy savings ever while reducing noise pollution and the consumption of valuable resources.

Cam and Ramp™ Lid removes easily, locks in place with a quick quarter-turn and is see-through for easy basket inspection

Diamond seals of oxidation-resistant, self-retaining EPDM rubber for longer life and a tighter seal

TEFC design keeps motor shielded from the elements for extended life

Innovative hydraulic isolator separates priming water from pumping water, smoothing the internal water flow for faster priming and greater efficiency—not just one or the other, like most pumps

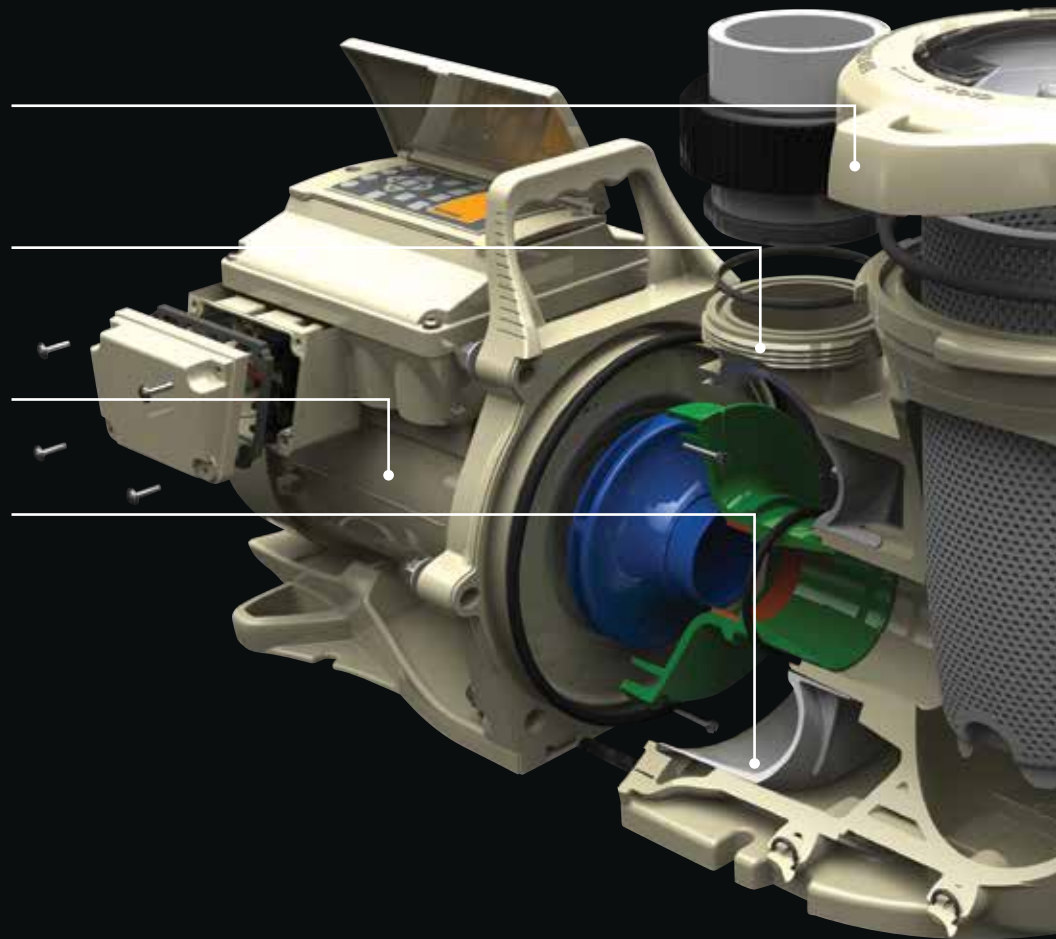

...HAS DONE IT AGAIN

SAVINGS UP TO

\$1,600

EACH YEAR



Union connectors are included for connecting directly to 2.5" or 3" plumbing

First, Pentair introduced IntelliFlo® Variable Speed Pump technology—an energy breakthrough that delivers estimated savings of up to 90% over traditional single-speed pumps. The IntelliFlo pump has outsold all other variable speed pumps combined.

Then we developed exclusive XF pump hydraulics. Using computerized Computational Fluid Dynamics and Finite Element Analysis, we optimized internal passageways and impellers to channel water through the pump more smoothly and efficiently than ever before.

Now, we've combined both these game-changing technologies to create the most efficient IntelliFlo pump we've ever made—offering massive energy savings for nearly every pool, from small and elegant to large and feature-rich. Meet the IntelliFloXF Variable Speed Pump. It's the one pump that lets you truly have it all.

ECONOMICAL

- Estimated cost savings of up to \$1,600 each year* versus traditional pumps.
- Even greater savings are achievable on larger pools—which are typically equipped with higher horsepower pumps.

Ultra-efficient permanent magnet motors, as used in advanced hybrid cars; achieves required flow rates with less effort than other pumps.

- Precise matching of motor speed to your pool's needs.
- 8 programmable speed settings and built-in timer assure optimum speed and run times, for maximum efficiency and savings.

POWERFUL

- Effortlessly powers large residential and feature-rich pools with waterfalls, slides, negative edges or other water features.
- Ideal for commercial pools, too.

QUIET

- The quietest pump on the planet—thanks to its permanent magnet motor, totally enclosed fan cooled (TEFC) design and the fact that it can operate at lower speeds.

DEPENDABLE

- Field-proven reliability no other variable speed brand can match.
- Variable speed operation improves filter and chlorinator performance; helps reduce algae build-up.
- Built-in self-diagnostics protect the pump.
- Permanent magnet motor runs cooler, produces less vibration than induction motors.

*Savings based on variable speed pump compared to single-speed pump running 12 hours per day at an average of \$0.16 kWh in a 20,000 gallon pool. Actual savings may vary based on local utility rates, pool size, pump run time, pump horsepower, pump rpm, plumbing size and length, pump model, service factor and other hydraulic factors.

ENERGY STAR® Certified IntelliFloXF pumps from Pentair meet strict energy efficiency criteria set by the U.S. Environmental Protection Agency and the U.S. Department of Energy. These pumps save money, reduce energy use and protect the environment.



INTELLIFLOXF[®]

VARIABLE SPEED PUMP

Extra-large, robust basket means fewer cleanings; smooth inner surface for easy debris removal

Built-in handle is a back-saver at the equipment pad

Modular plumbing system means less need to cut and glue pipe

External port threads and included tool-free unions need only hand-tightening for a perfect fit

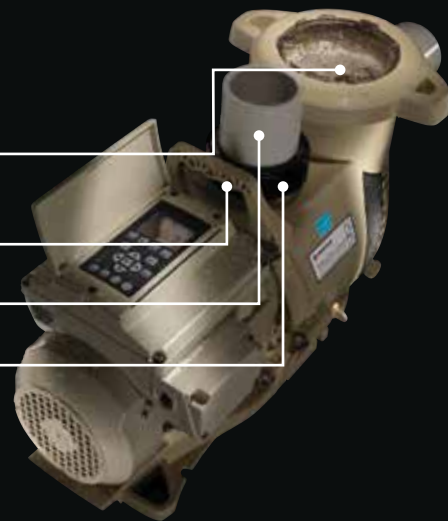

EASY TO INSTALL, EASY TO MANAGE.

The IntelliFloXF pump is an installer and pool owner's dream. It's a drop-in replacement for all WhisperFlo[®] High Performance Pump models and an easy substitute for Challenger[®] High Pressure Pumps.

Once installed, the IntelliFloXF pump is fully compatible with IntelliTouch[®], EasyTouch[®] and SunTouch[®] Control Systems, providing a range of options from indoor control panels to wireless remotes to manage pool heating, lighting, spa jets, water features and more. Add an optional ScreenLogic2[®] Interface, and IntelliTouch and EasyTouch system owners can enjoy pool and spa control using their PC or Mac[®] computer, iPhone[®], iPad[®] or iPod touch[®] mobile digital device.

The IntelliFloXF pump also works with other manufacturer's pool/spa controllers when used with a separately purchased IntelliComm[®] II Communication Center.

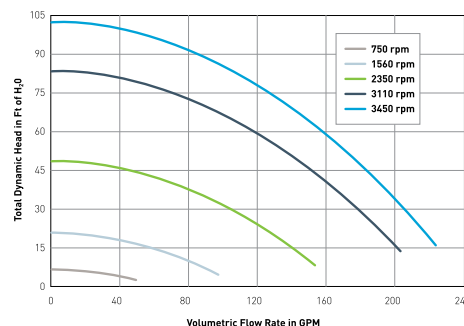

AVAILABLE FROM:



1620 HAWKINS AVE, SANFORD, NC 27330 800.831.7133 WWW.PENTAIRPOOL.COM

All Pentair trademarks and logos are owned by Pentair, Inc. IntelliFlo[®], Challenger[®], WhisperFlo[®], IntelliComm[®], EasyTouch[®], IntelliTouch[®], SunTouch[®], Eco Select[®], ScreenLogic2[®], IntelliFloXF[®] and Cam and Ramp[™] are trademarks and/or registered trademarks of Pentair Water Pool and Spa, Inc. and/or its affiliated companies in the United States and/ or other countries. Mac[®], iPad[®], iPhone[®] and iPod touch[®] are registered trademarks of Apple Inc. Because we are continuously improving our products and services, Pentair reserves the right to change specifications without prior notice. Pentair is an equal opportunity employer.

pumps • filters • heaters • heat pumps • automation • lighting • cleaners • sanitizers • water features • maintenance products

4/13 Part # P1-139 ©2013 Pentair Aquatic Systems. All rights reserved.